

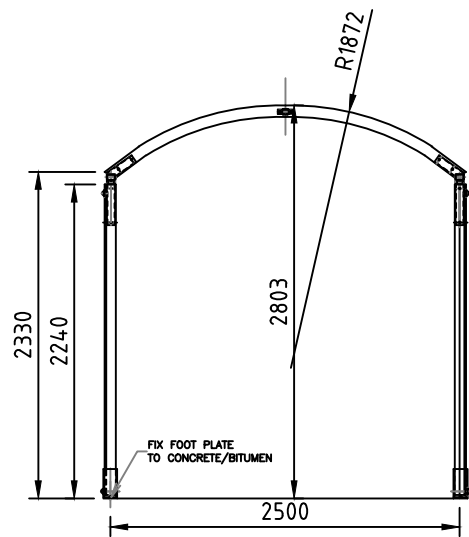

2.5m- WALK WAY-Technical Data

ITEM	SPECIFICATION
CLEAR - SPAN WIDTH	2.500m
EAVE HEIGHT	2.330m
RIDGE HEIGHT	2.803m
ROOF PITCH	CURVED - 1872R
BAY DISTANCE	3m / 5m
LONGEST COMPONENT	(3m: 3393m) / (5m: 5222m)
MINIMUM TENT LENGTH	3m
MAXIMUM TENT LENGTH	NO LIMITED
MAIN PROFILE	81 x 48 x 3mm (2 - CHANNEL)
MAX.ALLOWED WINDSPEED	80km / hour 0.3kn/m ₂
FRAMEWORK MATERIAL	HARD PRESSED EXTRUDED ALUMINIUM 6005A-T5
COVER MATERIAL	PVC- OPAQUE FABRIC, FLAME RETARDANT AS 1530.2 -PART 3 TEMP RESISTANCE: DIN 53361

	OPTIONAL ACCESSORIES
	PVC WINDOW SIDEWALLS SPIKE ANCHORING RAIN GUTTER LINING AND CURTAIN GLASS DOOR UNITS HARD WALLING SYSTEM GLASS WALL SYSTEM TRANSPARENT PVC COVER & SIDEWALL. FLOORING SYSTEM WEIGHT PLATE

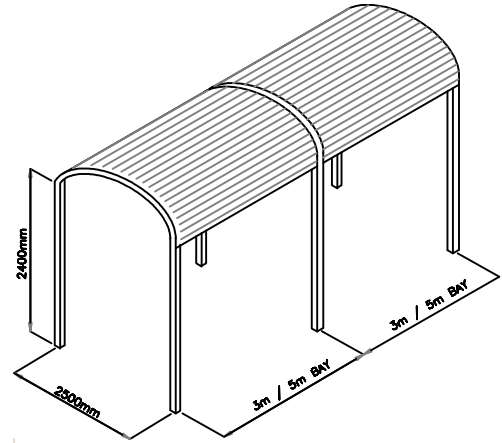

WALK WAY FRAME

FRAMEWORK MAIN PROFILE DIMENSION AND USE

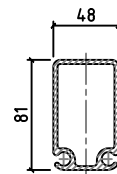

PHC-002
ROOF BEAMS
SIDE LEGS

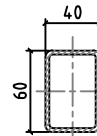

PHC-003
EVEAS PURLINS



PHC-008
CENTRE PURLIN

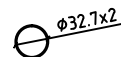

WALL & BRACE BAR